

Ohmite introduces the M series, patented (Pat. No. 7,151,669), high performance, low cost, configurable, scalable and compact heat sink with matrix clip system for TO-247 and TO-264 packages. This powerful heat sink provides the easiest assembly, largest surface area and smallest footprint. It is the ideal type of heat sink for high power density and small size (1U or 2U) electronic packaging with forced convection cooling.

## SPECIFICATIONS

**Heat Sink:** Aluminum Alloy 6063-T5 or Equivalent with either degreased or black anodized finish.

**Spring Clip:** Music Wire, Per ASTM A228 with bright nickel plating

**Solder Foot:** Cold-rolled Steel, Per ASTM A-366 with pure tin over copper strike. RoHS compliant.

**Interface thermal resistance:** for improvement, use thermal joint compound or 0.005 Grafoil (TGon 800 by Laird)

**Interface electrical isolation:** Sil-Pad 900S by Bergquist or equivalent

## HEAT DISSIPATION

For two devices. (L = 1.0")

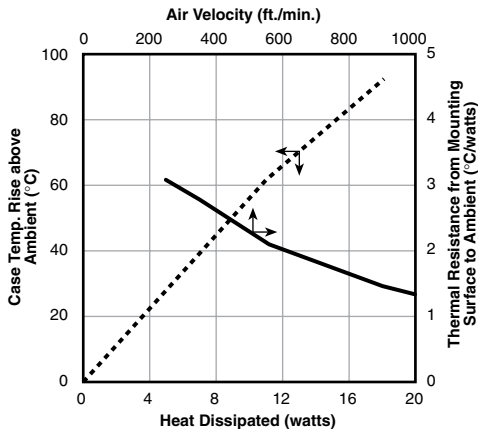

## ORDERING INFORMATION

No. of clips    RoHS Compliant  
**M V - 1 0 2 - 5 5 E**  
 Series    Finish    Length (mm)

A = black anodized  
 V = degreased

## FEATURES

- **Minimum assembly cost and labor.** Spring Clips make the mounting holes and fasteners obsolete in assembly operations & reduce costs.
- **Maximum Thermal Transfer.** Maximum surface area per unit volume, efficient cooling fins & consistent mounting force reduces thermal resistance
- **Maximum Repeatability.** Constant spring force over repeated assembly/disassembly
- **Maximum Reliability.** Resilient spring action locks electronic component in place. Fewer parts in assembly and no fasteners and washers required. Prevent short circuit by eliminating metal particles generated from hardware or thread tapping
- **Design Flexibility.** Maximum flexibility for dynamic device locations and power up grading. "Configure-to-Fit" & "Scale-to-Meet" options give designers the total freedom to configure the heat sink to fit their packaging designs and to scale the heat sink to meet their power dissipation.

# M Series Heatsinks

## Heatsink with two clips for TO-264 and TO-247

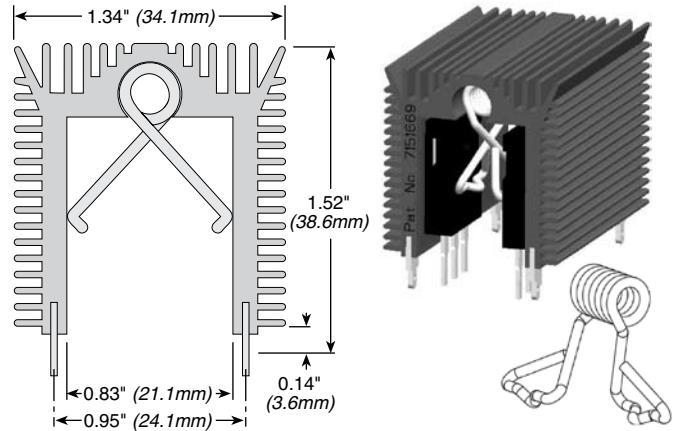

Part No.	Surface Area (in <sup>2</sup> /mm <sup>2</sup> )	Weight (oz./g)	Thermal Resistance (°C/w)*
MV-102-55E	45 / 29,097	2.2 / 63	5.8
MA-102-55E	45 / 29,097	2.2 / 63	5.2

\* R-theta<sub>c-a</sub> for 18W dissipation total for two devices in natural convection

## LAND PATTERN

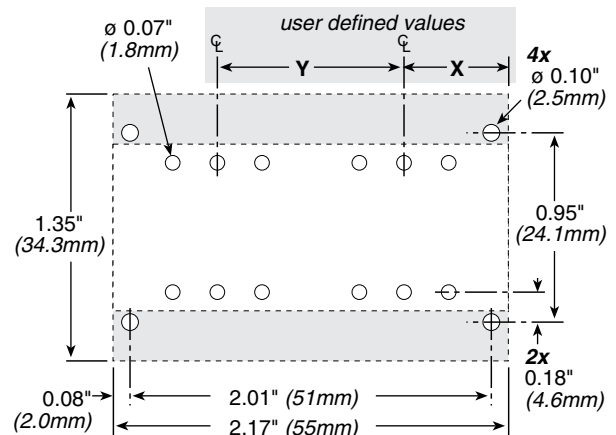

## STANDARD PART NUMBERS FOR M SERIES

Part Number	Description	Packaging
MV-102-55E	No finish (degreased)	Bulk
MA-102-55E	Black anodized	Bulk

**Check product availability  
 using the Worldwide Inventory  
 Search at [ohmite.com](http://ohmite.com)**